

High Performance Brushless DC Motor Controller with USB, and CAN Interface



Roboteq's HBL23xx is a high-power, dual channel controller for hall-sensor equipped Brushless DC motors. The controller uses the position information from the sensors to sequence power on the motors' 3 windings in order to generate smooth continuous rotation. The controller also uses the Hall sensor and/or Encoder information to compute speed and measure traveled distance inside a 32-bit counter. The motors may be operated in open or closed loop speed mode. The HBL23xx features several Analog, Pulse and Digital I/Os which can be remapped as command or feedback inputs, limit switches, or many other function. The HBL23xx accepts commands received from an RC radio, Analog Joystick, wireless modem, or microcomputer. For mobile robot applications, the controller's two motor channels can either be operated independently or mixed to move and steer a vehicle. Using CAN bus, up to 127 controllers can be networked at up to 1Mbit/s on a single twisted pair.

Numerous safety features are incorporated into the controller to ensure reliable and safe operation. The controller's operation can be extensively automated and customized using Basic Language scripts. The controller can be configured, monitored and tuned in real-time using a Roboteq's free PC utility. The controller can also be reprogrammed in the field with the latest features by downloading new operating software from Roboteq.

Applications

- Industrial Automation
- Small Electric Vehicles, Electric Bikes
- Terrestrial and Underwater Robotic Vehicles
- Automatic Guided Vehicles
- Police and Military Robots
- Hazardous Material Handling Robots
- Balancing Robots
- Telepresence Systems
- Animatronics

Key Features

- USB, RS232, 0-5V Analog, or Pulse (RC radio) command modes
- CAN bus interface up to 1Mbit/s
- Auto switch between USB, RS232, Analog, or Pulse based on user-defined priority
- Built-in dual 3-phase high-power drivers for two brushless DC motor at up to 75A
- Orderable in single channel 150A version (A-version only)
- Available in 60V and 96V versions
- Trapezoidal switching based on Hall Sensor position information
- Advanced Operating mode (A-version only)
 - Trapezoidal Sensorless
 - Sinusoidal with Encoders
 - Sinusoidal with Hall Sensors
- Support for absolute angle encoders (A-version only)
 - Sin/Cos analog
 - SSI
- Field Oriented Control in Sinusoidal modes (A-version only)
- Full forward and reverse control on each channel. Four quadrant operation. Supports regeneration
- Operates from a single power source
- Built-in programming language for automation and customization
- Programmable current limit for each channel up to 2x75A or 1x150A for protecting controller, motors, wiring and battery.
- Separate connector for Hall Sensors
- Accurate speed and Odometry measurement using Hall Sensor data
- Up to 11 Analog Inputs for use as command and/or feedback

- Up to six Pulse Length, Duty Cycle or Frequency Inputs for use as command and/or feedback
- Up to 21 Digital Inputs for use as Deadman Switch, Limit Switch, Emergency stop or user inputs
- Dual Quadrature Encoder inputs with 32-bit counters
- Eight general purpose 24V, 1A output for brake release or accessories
- Selectable min/max, center and deadband in Pulse and Analog modes
- Selectable exponentiation factors for each command inputs
- Trigger action if Analog, Pulse or Encoder capture are outside user selectable range (soft limit switches)
- Open loop or closed loop speed control operation
- Closed loop position control with analog or pulse/frequency feedback
- Precise speed and position control when Encoder feedback is used
- PID control loop with separate gains for each channel
- Optional Mixed control (sum and difference) for tank-like steering
- Configurable Data Logging of operating parameters on RS232 Output for telemetry or analysis
- Built-in Battery Voltage and Temperature sensors
- Optional 12V backup power input for powering safely the controller if the main motor batteries are discharged
- Power Control wire for turning On or Off the controller from external microcomputer or switch
- No consumption by output stage when motors stopped
- Regulated 5V output for powering Encoders, RC radio, RF Modem or microcomputer
- Separate Programmable acceleration and deceleration for each motor
- Separate Programmable maximum forward and reverse power
- Support for CANopen and three simplified CAN protocols
- Ultra-efficient 3 mOhm ON resistance MOSFETs
- Auto stop if no motion is detected
- Stall detection and selectable triggered action if Amps is outside user-selected range
- Short circuit protection with selectable sensitivity levels
- Overvoltage and Undervoltage protection
- Programmable Watchdog for automatic motor shutdown in case of command loss
- Overtemperature protection
- Diagnostic LED indicators
- Extruded aluminum, heat sinking enclosure for operation harsh shock and temperature environment
- Efficient heat sinking. Operates without a fan in most applications
- Dustproof and weather resistant. IP51 NEMA rating
- Power wiring via AWG8 battery cables and AWG10 motor cables
- Dimensions: 9" (228.5mm) L, 5.5" W (140mm), 1.6" (40mm) H
- A -40° to +85° C operating environment
- Weight: 3 lbs (1,340g)
- Easy configuration, tuning and monitory using provided PC utility
- Field upgradeable software for installing latest features via the Internet

Orderable Product References

Reference	Number of Channels	Amps/Channel	Volts	Sinusoidal
HBL2360	2	75	60	No
HBL2396	2	50	96	No
HBL2360A	2	75	60	Yes
HBL2360AS	1	150	60	Yes
HBL23120	2	40	120	Yes

Important Safety Disclaimer

Dangerous uncontrolled motor runaway condition can occur for a number of reasons, including, but not limited to: command or feedback wiring failure, configuration error, faulty firmware, errors in user script or user program, or controller hardware failure.

The user must assume that such failures can occur and must make his/her system safe in all conditions. Roboteq will not be liable in case of damage or injury as a result of product misuse or failure.

Hardware Revisions

The HBL23xx family has undergone two updates and a major redesign since its introduction. The original and its updated revisions share the HBL23xx product reference, plus the codes RC5 and RC53 marked on the label located on the bottom side of the case. The new design is referred as HBL23xxA. Newer versions are hardware and functionality backwards compatible with earlier versions. Unless otherwise noted, information in this datasheet applies to all hardware versions.

Power Wires Identifications and Connection

Power connections are made by means of heavy gauge wires located at the back of the controller, as shown in Figure 1.

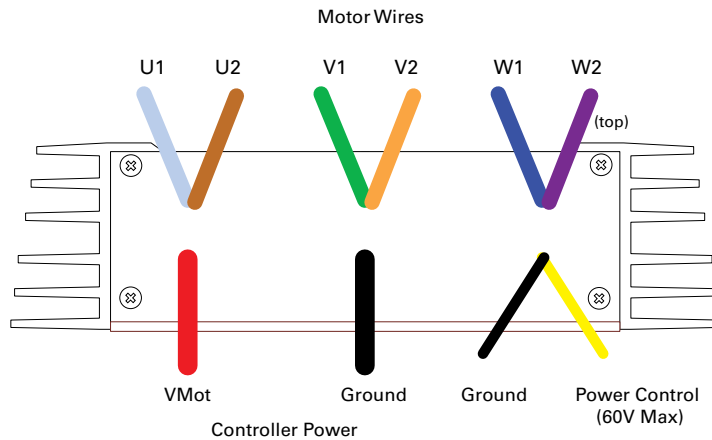

FIGURE 1. Rear Controller Layout

Figure 2, below, shows how to wire the controller and how to turn power On and Off.

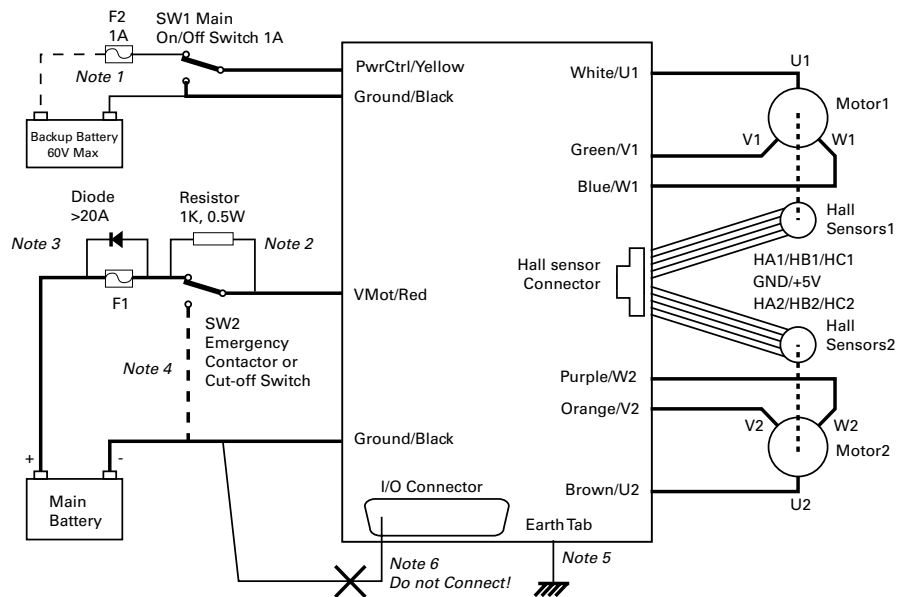

FIGURE 2. Powering the Controller. Thick lines identify MANDATORY connections

Important Warning

Carefully follow the wiring instructions provided in the Power Connection section of the User Manual. The information on this datasheet is only a summary.

Mandatory Connections

It is imperative that the controller is connected as shown in the diagram in Figure 2, above, in order to ensure a safe and trouble-free operation. All connections shown as thick black lines are mandatory. The controller must be powered On/Off using switch SW1 on the Yellow wire. Use a suitable high-current fuse F1 as a safety measure to prevent damage to the wiring in case of major controller malfunction.

Emergency Switch or Contactor

The battery must be connected in permanence to the controller's Red wires via a high-power emergency switch or contactor SW2 as additional safety measure. The user must be able to deactivate the switch or contactor at any time, independently of the controller state.

Electrostatic Discharge Protection

In accordance with IEC 61000-6-4, Roboteq Motor Controllers are designed to withstand ESD up to 4kV touch and 8kV air gap. This protection is implemented without any additional external connections required.

Some specifications, such as EN12895, require a higher level of protection. To maximize ESD protection, up to 8kV touch and 15kV air gap, you may connect the metallic heatsink of the controller to your battery negative terminal. [See App Note 062918 for example connections.](#)

Precautions and Optional Connections

Note 1: Backup battery to ensure motor operation with weak or discharged batteries, connect a second battery to the Power Control wire/terminal via the SW1 switch. For 96V and 120V version controllers, the maximum voltage that should be applied to Power Control (PwrCtrl) is 60V. Applying a voltage >60V to PwrCtrl will damage the controller.

Note 2: Use precharge 1K, 0.5W Resistor to prevent switch arcing.

Note 3: Insert a high-current diode to ensure a return path to the battery during regeneration in case the fuse is blown.

Note 4: Optionally ground the VMot wires when the controller is Off if there is any concern that the motors could be made to spin and generate voltage in excess of 60V (HBL2360), 96V (HBL2396) or 120V (HBL23120).

Note 5: Connect the controller's earth tab to a wire connected to the Earth while the charger is plugged in the AC main, or if the controller is powered by an AC power supply.

Note 6: Beware not to create a path from the ground pins on the I/O connector and the battery minus terminal.

Single Channel Wiring (A-Version only)

On the Single Channel HBL23xxAS, each of the motor wires must be connected to both wires of the same letter as shown in Figure 3 below. Use the Encoders and/or Hall sensors of Channel 1 for operation.

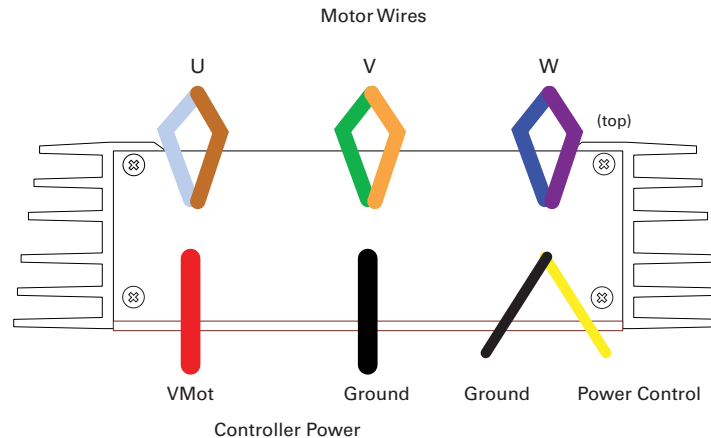

FIGURE 3. Single Channel Wiring Diagram

Important Warning

Single channel operation is only possible on the newer, A version of the controller. This wiring must be done only on the single channel version of the controller. Paralleling the wires on a dual channel product will cause permanent damage. Verify that your controller is an HBL2360AS or HBL2396AS before you wire in this manner.

Use of Safety Contactor for Critical Applications

An external safety contactor must be used in any application where damage to property or injury to person can occur because of uncontrolled motor operation resulting from failure in the controller's power output stage.

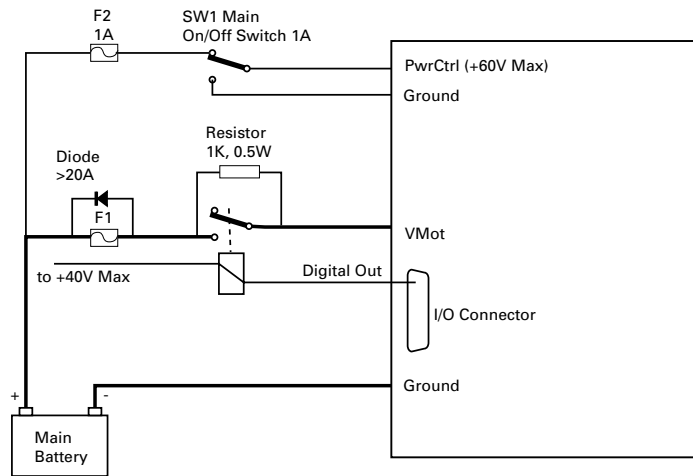

FIGURE 4. Contactor Wiring Diagram

Note: This wiring should not be used for 96V or 120V version controllers HBL2396 or HBL23120. This would apply a voltage >60V to PwrCtrl and damage the controller. The wiring shown in FIGURE 2 is recommended for the HBL2396.

The contactor coil must be connected to a digital output configured to activate when “No MOSFET Failure”. The controller will automatically deactivate the coil if the output is expected to be off and battery current of 1A or more is measured for more than 0.5s. This circuit will not protect against other sources of failure such as those described in the “Important Safety Disclaimer” on Page 3.

Controller Mounting

During motor operation, the controller will generate heat that must be evacuated. The published amps rating can only be fully achieved if adequate cooling is provided. Always operate the controller in a well ventilated space so that air can flow between the heat-sink fins. Additional conduction cooling can be achieved by having the bottom edges of the case making contact with a metallic surface (chassis, cabinet).

Hall Sensors Connection

Connection to the Hall Sensors is done using a special connector on the front side of the controller. Figure 5, below, shows the location of the various low-voltage connectors and LEDs on the controller.

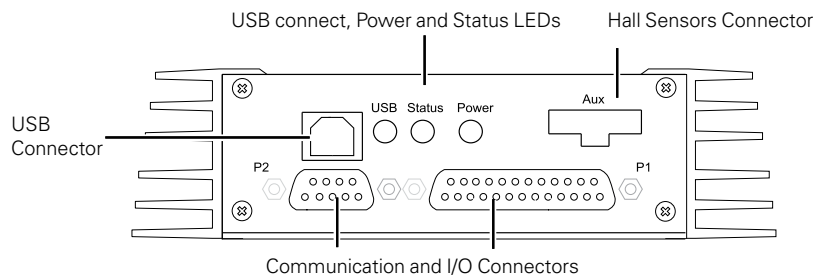

FIGURE 5. Front Controller Layout

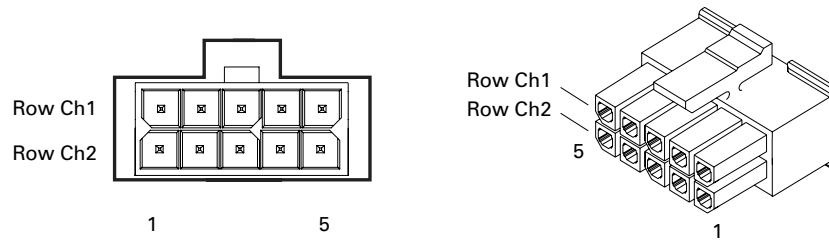

FIGURE 6. Hall Sensors Connector

TABLE 1.

Pin Number	1	2	3	4	5
Row Ch1	5V	Hall1 C	Hall1 B	Hall1 A	Ground
Row Ch2	5V	Hall2 C	Hall2 B	Hall2 A	Ground

Hall Sensor vs Motor Output sequencing

The controller requires the Hall sensors inside the motor to be 120 degrees apart. The controller's 3-phase bridge will activate each of the motor winding according to the sequence shown in Figure 7, below.

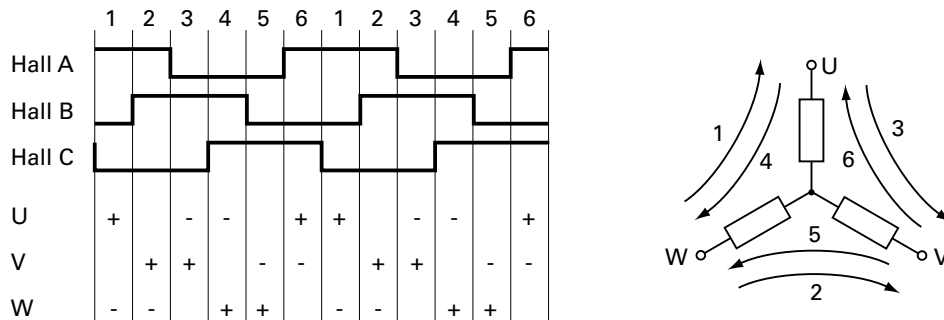

FIGURE 7. Hall Sensors Sequence

Connection to SSI Absolute Encoder

On models HDC23xxA, when operating in Sinusoidal Mode, the controller can use motors equipped with absolute angle sensors with SSI interface. When enabled, the SSI signals are found on the 10-pin Molex connector that is otherwise used for the Hall Sensors. The controller issues a differential clock signal and expects a 12-bit differential data signal from the encoder. When two motors are used, the clock must be connected to both sensors. Serial data from each sensor is captured on separate input pins.

TABLE 2.

Pin Number	1	2	3	4	5
Row 1	5V	CLK -	Data 2 -	Data 1 -	GND
Row 2	5V	Clock +	Data 2 +	Data 1 +	GND

Connection to Analog Sin/Cos Absolute Encoder

The HBL23xxA has 4 high-speed analog inputs that can be used to capture absolute angle positions from resolvers or magnetic sensors with Sin/Cos voltage outputs. The signal must be 0-5V max with the 0 at 2.500V. Table 3 shows the signal assignments on the 25- pin connector.

TABLE 3.

Signal	Pin Number	Pin Name
Sin1	12	ASIN1
Cos1	24	ACOS1
Sin2	11	ANA7/ASIN2
Cos2	23	ANA8/ACOS2

Commands and I/O Connections

Connection to RC Radio, Microcomputer, Joystick and other low current sensors and actuators is done via the 25 and 9 pin connectors located in front of the connector. The functions of many pins vary depending on controller model and user configuration. Pin assignments are found in Table 4, below.

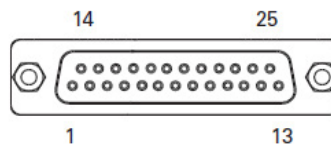

FIGURE 8. Main Connector Pin Locations

TABLE 4.

Connector Pin	Power	Dout	Com	Pulse	Ana	Dinput	Enc	Default Config
1	GND							
14	5VOut							
2			TxData					RS232Tx
15				PIN1	ANA1	DIN1		RCRadio1
3			RxData					RS232Rx
16				PIN2	ANA2	DIN2		RCRadio2
4				PIN3	ANA3	DIN3		AnaCmd1 (1)
17				PIN4	ANA4	DIN4		AnaCmd2 (1)
5	GND							
18		DOUT1				DIN12		Motor Brake 1
6		DOUT2				DIN13		Motor Brake 2
19		DOUT3				DIN14		Contactora
7		DOUT4				DIN15		Unused
20		DOUT5				DIN16		Unused
8		DOUT6				DIN17		Unused
21				PIN5 (2)	ANA5	DIN5		Unused
9	GND							
22				PIN6 (2)	ANA6	DIN6		Unused

TABLE 4.

Connector Pin	Power	Dout	Com	Pulse	Ana	Dinput	Enc	Default Config
10					ANA7	DIN7		Unused
23					ANA8 COS2 (2)	DIN8	ENC2B	Unused
11					ANA9 SIN2 (2)	DIN9	ENC2A	Unused
24					ANA10 COS1 (2)	DIN10	ENC1B	Unused
12					ANA11 SIN1 (2)	DIN11	ENC1A	Unused
25	5VOut							
13	GND							

Note 1: Analog command is disabled in factory default configuration.

Note 2: Available only on HBL2xxxA

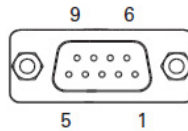

FIGURE 9. Secondary Connector Pin Locations

TABLE 5.

Connector Pin	Power	Dout	Com	Pulse	Ana	Dinput	Default Config
5		DOUT7				DIN18	Unused
9	5VOut						
4			RS485+ (1)				RS485+
8			RS485- (1)				RS485-
3	GND						
7			CANH				CAN High
2			CANL				CAN Low
6	GND						
1		DOUT8				DIN19	Unused

Note 1: Available only on HBL2xxxA

Default I/O Configuration

While the controller can be configured so that practically any Digital, Analog and RC pin can be used for any purpose, the controller's factory default configuration provides an assignment that is suitable for most applications. The figure below shows how to wire the controller to two analog potentiometers, an RC radio, and the RS232 port. It also shows how to connect two outputs to motor brake solenoids and another output to an external status LED. You may omit any connection that is not required in your application. The controller automatically arbitrates the command priorities depending on the presence of a valid command signal in the following order: 1-RS232, 2-RC Pulse, 3-None. If needed, use the Roborun+ PC Utility to change the pin assignments and the command priority order.

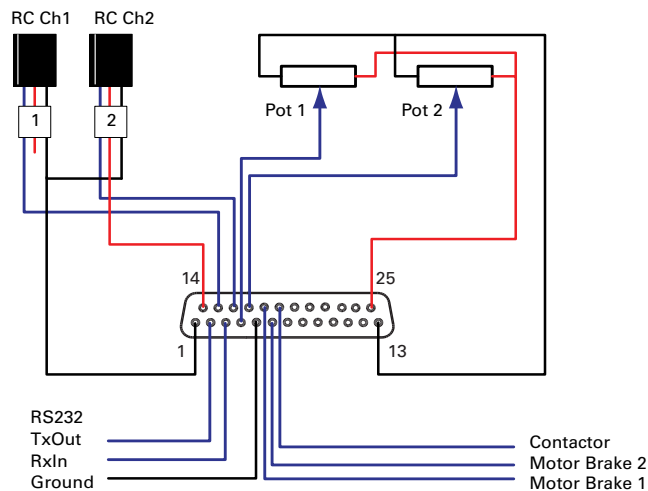

FIGURE 10. Factory default pins assignment

Enabling Analog Commands

For safety reasons, the Analog command mode is disabled by default. To enable the Analog mode, use the PC utility and set Analog in Command Priority 2 or 3 (leave Serial as priority 1). Note that by default the additional securities are enabled and will prevent the motor from starting unless the potentiometer is centered, or if the voltage is below 0.25V or above 4.75V. The drawing shows suggested assignment of Pot 1 to ANA1 and Pot 2 to ANA4. Use the PC utility to enable and assign analog inputs.

Serial Communication

The controller has a full RS232 compatible serial interface. In HBL23xxA models, the serial port can also easily be connected to devices with TTL serial using a simple resistor and diodes circuit. See user manual for details.

CAN Bus Operation

The controller can interface to a standard CAN Bus network, using three possible protocols: Standard CANOpen, and three proprietary schemes (MiniCAN, RoboCAN and RawCAN). Please refer to the User Manual for details. Note that version labeled R5, USB and CAN cannot operate at the same time. The controller starts up with CAN available, but CAN will be disabled as soon as the controller is plugged into USB. To re-enable CAN, disconnect USB and restart the controller. On HBL23xxA models and models labeled R53, USB and CAN can be operated simultaneously.

RS485 Communication

The HBL23xxA has a half-duplex RS485 interface. Two signals are present on the 9-pin DSub connector for connecting to RS485 networks. Connecting these two wires with the correct polarity is all that is needed to establish a connection. The RS485+ is the positive signal and RS485- is the inverted signal. Once enabled, the RS485 can be used to communicate data under the Modbus protocol, or Roboteq's native serial commands.

Status LED Flashing Patterns

After the controller is powered on, the Power LED will turn on, indicating that the controller is On. The Status LED will be flashing at a two seconds interval. The flashing pattern and color provides operating or exception status information. Note that earlier versions of the HBL23xx hardware labeled r5 have a monochrome status LED.



FIGURE 11. Normal Operation Flashing Patterns

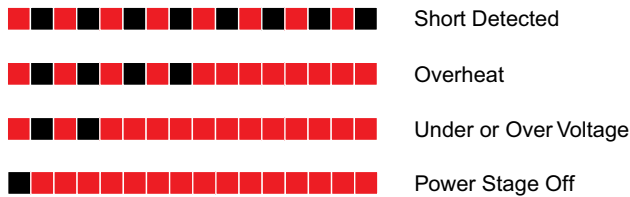

FIGURE 12. Exception or Fault Flashing Patterns

Additional status information may be obtained by monitoring the controller with the PC utility.

The communication LED gives status information on the CAN and USB.

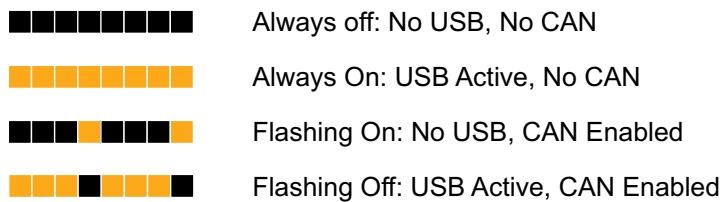

FIGURE 13. Com LED

Measured and Calculated Amps

HBL23xx models include Amps sensor in line with the battery ground wires. Battery Amps are therefore measured with precision. Motor Amps are estimated using the formula $\text{Motor Amps} = \text{Battery Amps} / \text{PWM}$. This formula produces accurate results from 20% PWM and above. No Motor Amps are reported at 0% PWM.

HBL23xxA models include Amps sensors in line with the motor terminals and on the battery ground terminals. On these models, both Motor Amps and Battery Amps are therefore measured with precision.

Battery Backed Clock and RAM

The controller includes a real-time clock/calendar and Non-Volatile RAM storage for user variables. Both the clock and the RAM storage require a battery to continue running and for the stored data not to be lost while the controller is powered down. The battery is not installed by Roboteq. Users who wish to use the clock and/or battery backed RAM variables must install a battery themselves. The battery socket can be reached by removing the bottom cover to reach the board and insert a 3V, 12.5mm coin-style battery. Use battery type CR1225 or equivalent. Battery holder is present only in the HBL23xxA version

Electrical Specifications

Absolute Maximum Values

The values in Table 6, below, should never be exceeded. Permanent damage to the controller can result

TABLE 6.

Parameter	Measure point	Models	Min	Typical	Max	Units
		HBL2360			60	Volts
		HBL2396	36		100	Volts
		HBL23120	36		130	Volts
Reverse Voltage on Battery Leads	Ground to VMot	All	-1			Volts
Power Control Voltage	Ground to Pwr Control wire	All			60	Volts
Motor Leads Voltage	Ground to M1+, M1-, M2+, M2-	HBL2360			60 (1)	Volts
		HBL2396	36		96 (1)	Volts
Digital Output Voltage	Ground to Output pins	All			40	Volts
Analog and Digital Inputs Voltage	Ground to any signal pin on 25 & 9-pin connectors	All			30	Volts
RS232 I/O pins Voltage	External voltage applied to Rx pin	All			30 (2)	Volts
Case Temperature	Case	All	-40		85	°C
Humidity	Case	All			100 (3)	%
Note 1: Maximum regeneration voltage in normal operation. Never inject a DC voltage from a battery or other fixed source Note 2: No voltage must be applied to the RS232 Tx pin Note 3: Non condensing						

Power Stage Electrical Specifications (at 25°C ambient)

TABLE 7.

Continuous Max Current per channel	Measure point	Models	Min	Typical	Max	Units
Battery Leads Voltage	Ground to VMot	HBL2360	0 (1)		60	Volts
		HBL2396	36 (1)		100	Volts
		HBL23120	36 (1)		120	Volts
Motor Leads Voltage	Ground to U, V, W wires	HBL2360	0 (1)		60 (2)	Volts
		HBL2396	36 (1)		100 (2)	Volts
		HBL23120	36 (1)		120 (2)	Volts
Power Control Voltage	Ground to Power Control wire	All	0 (1)		60	Volts
Minimum Operating Voltage	VMot or Pwr Ctrl wires	All	9 (3)			Volts
Over Voltage protection range	Ground to VMot	HBL2360	5	60 (4)	60	Volts
		HBL2396	5	100 (4)	100	Volts
		HBL23120	5	120 (4)	130	Volts
Under Voltage protection range	Ground to VMot	HBL2360	0	5 (4)	60	Volts
		HBL2396	0	5 (4)	100	Volts
		HBL23120	0	5 (4)	100	Volts
Idle Current Consumption	VMot or Pwr Ctrl wires	All	50	100(5)	150	mA
ON Resistance (Excluding wire resistance)	VMot to U, V or W. Ground to U, V or W	All		6		mOhm
Max Current for 30s	Motor current	HBL2360			75 (6)	Amps
		HBL2360S			150 (6)	
		HBL2396			50 (6)	
		HBL2396S			100 (6)	
		HBL23120			40	
		HBL23120S			80	
Continuous Max Current per channel	Motor current	HBL2360			50 (7)	Amps
		HBL2360S			100 (7)	
		HBL2396			35 (7)	
		HBL2396S			70 (7)	
		HBL23120			25 (7)	
		HBL23120S			50 (7)	

TABLE 7.

Continuous Max Current per channel	Measure point	Models	Min	Typical	Max	Units
Current Limit range	Motor current	HBL2360	10	50 (8)	75	Amps
		HBL2360S	10	100 (8)	150 (7)	
		HBL2396	10	40 (8)	50	
		HBL2396S	10	80 (8)	100	
		HBL23120	10	30 (8)	40	
		HBL23120S	10	60 (8)	80	
Stall Detection Amps range	Motor current	HBL2360	10	75 (8)	75	Amps
		HBL2360S	10	150 (8)	150 (7)	
		HBL2396	10	50 (8)	50	
		HBL2396S	10	100 (8)	100	
		HBL23120	10	40 (8)	40	
		HBL23120S	10	40 (8)	80	
Stall Detection timeout range	Motor current	All	1	500 (9)	65000	milli-seconds
Short Circuit Detection threshold (10)	Between Motor wires or Between Motor wires and Ground	All	140 (11)		400 (11)	Amps
Short Circuit Detection threshold	Between Motor wires and VMot	All	No Protection. Permanent damage will result			
Motor Acceleration/Deceleration range	Motor Output	All	100	500 (12)	65000	milli-seconds
<p>Note 1: Negative voltage will cause a large surge current. Protection fuse needed if battery polarity inversion is possible</p> <p>Note 2: Maximum regeneration voltage in normal operation. Never inject a DC voltage from a battery or other fixed source</p> <p>Note 3: Minimum voltage must be present on VMot or Power Control wire</p> <p>Note 4: Factory default value. Adjustable in 0.1V increments</p> <p>Note 5: Current consumption is lower when higher voltage is applied to the controller's VMot or PwrCtrl wires</p> <p>Note 6: Max value is determined by current limit setting. Duration is estimated and is dependent on ambient temperature cooling condition</p> <p>Note 7: Estimate. Limited by case temperature. Current may be higher with better cooling</p> <p>Note 8: Factory default value. Adjustable in 0.1A increments</p> <p>Note 9: Factory default value. Time in ms that Stall current must be exceeded for detection</p> <p>Note 10: Controller will stop until restarted in case of short circuit detection</p> <p>Note 11: Sensitivity selectable by software</p> <p>Note 12: Factory default value. Time in ms for power to go from 0 to 100%</p>						

Command, I/O and Sensor Signals Specifications

TABLE 8.

Parameter	Measure point	Min	Typical	Max	Units
Main 5V Output Voltage	Ground to 5V pins on	4.6	4.75	5.1	Volts
5V Output Current	5V pins on RJ45 and DSub15			100 (1)	mA

TABLE 8.

Parameter	Measure point	Min	Typical	Max	Units
Digital Output Voltage	Ground to Output pins			30	Volts
Digital Output Current	Output pins, sink current			1 (2)	Amps
Output On resistance	Output pin to ground		0.75	1.5	Ohm
Output Short circuit threshold	Output pin	1.05	1.4	1.75	Amps
Input Impedances	AIN/DIN Input to Ground		53		kOhm
Digital Input 0 Level	Ground to Input pins	-1		1	Volts
Digital Input 1 Level	Ground to Input pins	3		30	Volts
Analog Input Range	Ground to Input pins	0		5.1	Volts
Analog Input Precision	Ground to Input pins		0.5		%
Analog Input Resolution	Ground to Input pins		1		mV
Pulse durations	Pulse inputs	20000		10	us
Pulse repeat rate	Pulse inputs	50		250	Hz
Pulse Capture Resolution	Pulse inputs		1		us
Frequency Capture	Pulse inputs	100		2000	Hz
Encoder count	Internal	-2.147		2.147	10 ⁹ Counts
Encoder frequency	Encoder input pins			250	kHz
Note 1: Sum of all 5VOut outputs					
Note 2: Total average current on all outputs not to exceed 4.5A					

Operating & Timing Specifications

TABLE 9.

Parameter	Measure Point	Min	Typical	Max	Units
Command Latency	Command to output change	1	0.5	1	ms
PWM Frequency	Ch1, Ch2 outputs	10	16 (1)	20	kHz
Closed Loop update rate	Internal		1000		Hz
USB Rate	USB pins			12	Mbits/s
RS232 baud rate	Rx & Tx pins		115200 (2)		Bits/s
RS232 Watchdog timeout	Rx pin	1 (3)		65000	ms
Note 1: May be adjusted with configuration program					
Note 2: 115200, 8-bit, no parity, 1 stop bit, no flow control					
Note 3: May be disabled with value 0					

Scripting

TABLE 10.

Parameter	Measure Point	Min	Typical	Max	Units
Scripting Flash Memory	Internal		32000		Bytes
Max Basic Language programs	Internal	1000		3000	Lines
Integer Variables	Internal		4096		Words (1)
Boolean Variables	Internal		8192		Symbols
Execution Speed	Internal	50 000	100 000		Lines/s
Note 1: 32-bit words					

Thermal Specifications

TABLE 11.

Parameter	Measure Point	Model	Min	Typical	Max	Units
Case Temperature	Case	All	-40		85 (1)	°C
Thermal Protection range	Case	All	80		90 (2)	°C
Power Dissipation	Case	All			70	Watts
Thermal resistance	Power MOSFETs to case	All			0.6	°C/W
Note 1: Thermal protection will protect the controller power						
Note 2: Max allowed power out starts lowering at minimum of range, down to 0 at max of range						

Mechanical Specifications

TABLE 12.

Parameter	Measure Point	Min	Typical	Max	Units
Weight	Case		1340 (2.95)		g (lbs)
Wire Length	Case		17 (43)		inches (mm)
Power Wires Gauge	Wire		8		AWG
Motor Wires Gauge	Wire		10		AWG

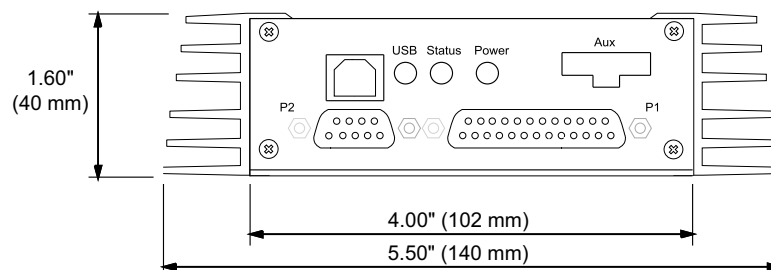

FIGURE 14. HBL23xx Front View and Dimensions

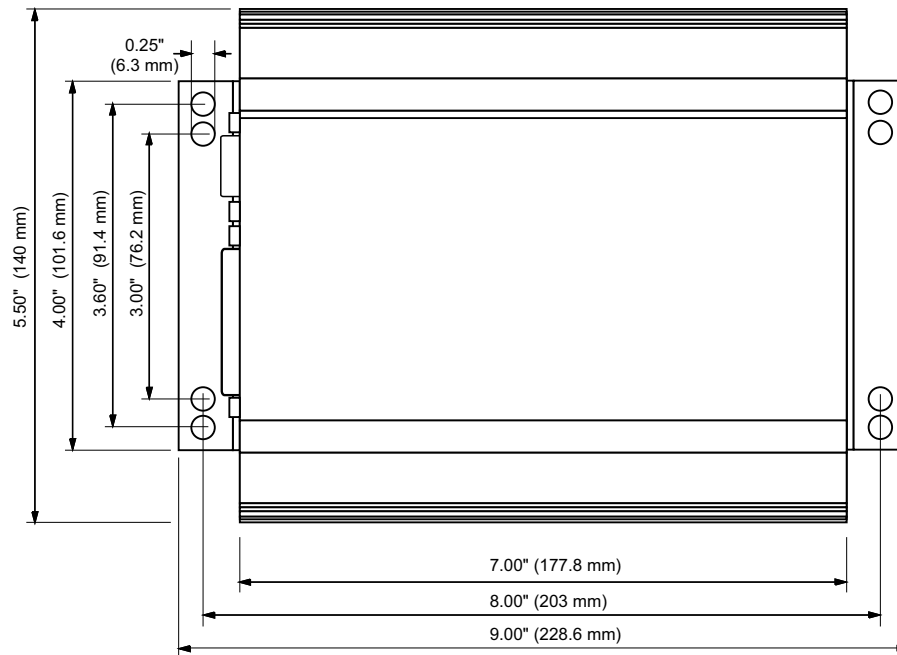

FIGURE 15. HBL23xx Top View and Dimensions