

High Power 2 x 180A or 1 x 360A Brushless DC Motor Controller with USB, CAN and Ethernet

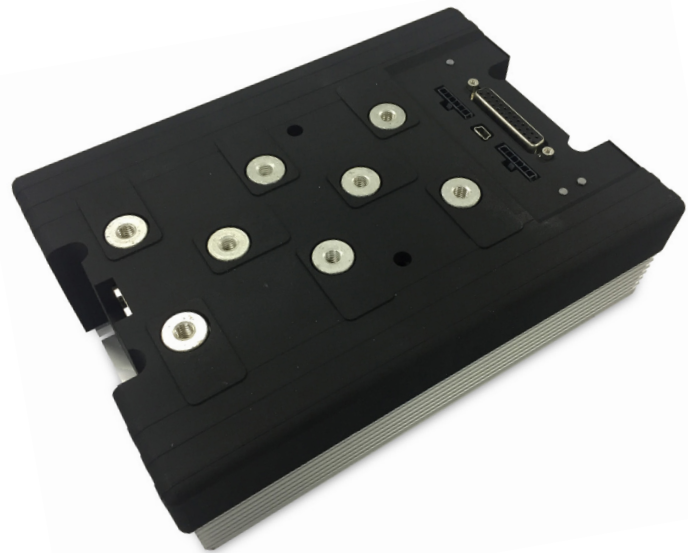

Roboteq's GBL26xx is a feature-packed, high-current, dual or single channel controller for brushless Permanent Magnets AC or DC Synchronous motors. The controller also uses the Hall sensor and/or most types of Encoders to capture the Rotor position and measure traveled distance. The motors may be operated in open or closed loop speed mode, position mode or in torque mode. The GBL26xx features several Analog, Pulse and Digital I/Os which can be remapped as command or feedback inputs, limit switches, or many other functions. The GBL26xx accepts commands received from an RC radio, Analog Joystick, wireless modem, or microcomputer. For mobile robot applications, the controller's two motor channels can either be operated independently or mixed to move and steer a vehicle. Using CAN bus, up to 127 controllers can be networked at up to 1Mbit/s on a single twisted pair. An optional Ethernet port with PC allows the connection to PLCs and TCP/IP networks.

Numerous safety features are incorporated into the controller to ensure reliable and safe operation. The controller's operation can be extensively automated and customized using Basic Language scripts. The controller can be configured, monitored and tuned in real-time using a Roboteq's free PC utility. The controller can also be reprogrammed in the field with the latest features by downloading new operating software from Roboteq.

Applications

- Automatic Guided Vehicles
- Small Electric Vehicles, Electric Bikes
- Terrestrial and Underwater Robotic Vehicles
- Police and Military Robots
- Hazardous Material Handling Robots
- Balancing Robots
- Telepresence Systems
- Animatronics

Key Features

- USB, Serial, 0-5V Analog, or Pulse (RC radio) command modes
- One serial port
- CAN bus interface up to 1Mbit/s with multiple protocol support
- RS485 Optional Ethernet interface
- Optional 10/100 Ethernet
- Auto switch between Serial, USB, CAN, Analog, or Pulse based on user-defined priority
- Built-in dual 3-phase high-power drivers for two brushless DC motor at up to 180A
- Output channels can be paralleled in order to drive a single motor at up to 360A
- Multiple Motor Operating mode
 - Trapezoidal with Hall Sensors
 - Trapezoidal Sensorless
 - Sinusoidal with Incremental Encoder
 - Sinusoidal with SSI Encoder
 - Sinusoidal with Resolver
 - Sinusoidal with Hall Sensors
 - Sinusoidal with Sin/Cos Encoder
- Field Oriented Control in Sinusoidal modes
- Full forward & reverse motor control. Four quadrant operation. Supports regeneration
- Operates from a single 10V to 60V power source
- Programmable current limit up to 180A (360A on single channel version) per motor for protecting controller, motor, wiring and battery.
- Separate connector for Hall Sensors
- Accurate speed and Odometry measurement using Hall Sensor or Encoder data

- Up to eight Analog Inputs for use as command and/or feedback
- Up to eight Pulse Length, Duty Cycle or Frequency Inputs for use as command and/or feedback
- Up to 10 Digital Inputs for use as Deadman Switch, Limit Switch, Emergency stop or user inputs
- Inputs for up to 3 Quadrature Encoders
- 4 general purpose 1.5A output for brake release or accessories
- Selectable min, max, center and deadband in Pulse and Analog modes
- Selectable exponentiation factors for each command inputs
- Trigger action if Analog, Pulse or Hall counter capture are outside user selectable range (soft limit switches)
- Open loop or closed loop speed control operation
- Closed loop position control with encoder, hall sensors, analog or pulse/frequency feedback
- Torque mode
- PID control loop
- Built-in Battery Voltage and Temperature sensors
- Optional 12V backup power input for powering safely the controller if the main motor batteries are discharged
- Power Control wire for turning On or Off the controller from external microcomputer or switch
- No consumption by output stage when motors stopped
- Regulated 5V output for powering RC radio, RF Modem, sensors or microcomputer
- Separate Programmable acceleration and deceleration for each motor
- Ultra-efficient 1.2 mOhm ON resistance MOSFETs (0.6 mOhm on Single Channel)
- Stall detection and selectable triggered action if Amps is outside user-selected range
- Short circuit protection
- Overvoltage and Undervoltage protection
- Watchdog for automatic motor shutdown in case of command loss
- Overtemperature protection
- Diagnostic LED indicators
- ABS plastic enclosure with heat conducting bottom plate
- Efficient heat sinking. Operates without a fan in most applications.
- Built-in conduits for liquid cooling
- Dustproof and weather resistant. IP51 NEMA rating
- Power wiring using High Current M6 screw terminals
- 210mm x 145mm x 60mm
- -40° to +85° C operating environment
- Weight: 6.5 lbs (2940g)
- Easy configuration, tuning and monitoring using provided PC utility
- Field upgradeable software for installing latest features via the Internet Orderable Product References

Orderable Product References

Reference	Number of Channels	Amps/Channel	Volts	Ethernet	Resolver
GBL2660	2	180	60	No	No
GBL2660E	2	180	60	Yes	No
GBL2660S	1	360	60	No	No
GBL2660SE	1	360	60	Yes	No

Important Safety Disclaimer

Dangerous uncontrolled motor runaway condition can occur for a number of reasons, including, but not limited to: command or feedback wiring failure, configuration error, faulty firmware, errors in user script or user program, or controller hardware failure.

The user must assume that such failures can occur and must make his/her system safe in all conditions. Roboteq will not be liable in case of damage or injury as a result of product misuse or failure.

Power Wires Identifications and Connection

Power connections are made by means of high amperage power terminals located at the top of the controller, as shown in Figure 1:.

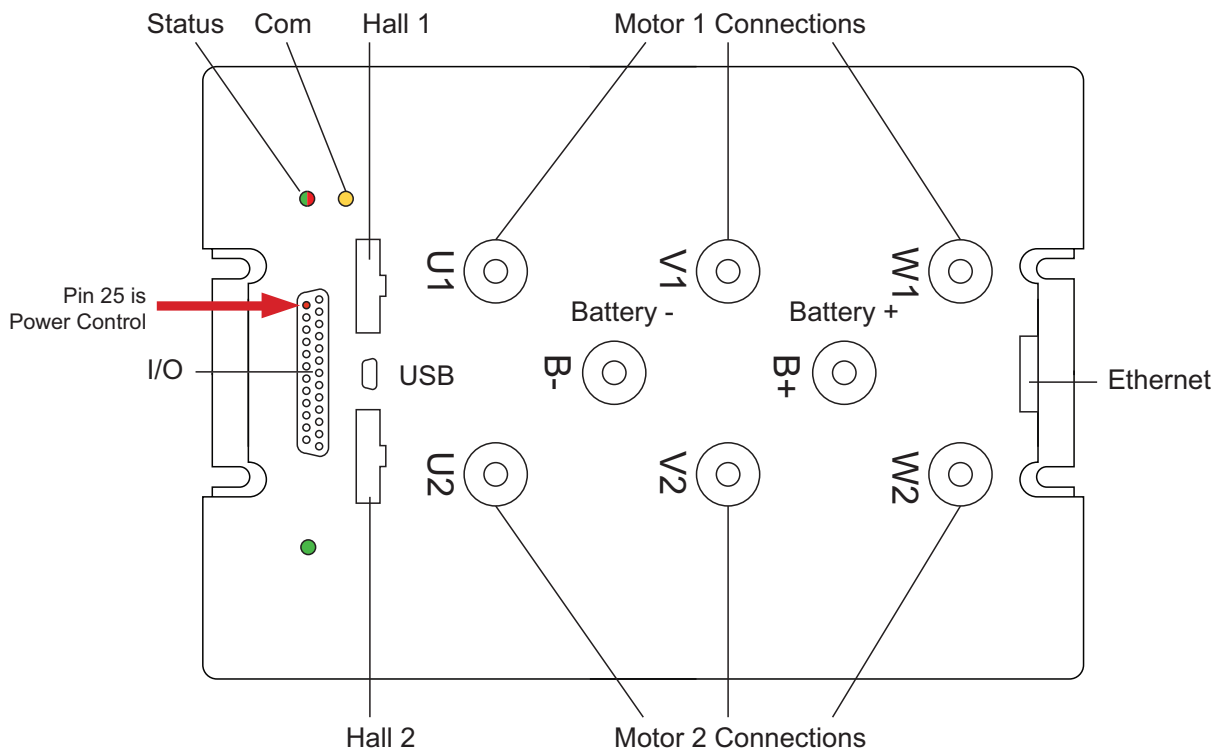

FIGURE 1. GBL26xx Rear View

The diagram in Figure 2, below, shows how to wire the controller in a dual motor configuration, and how to turn power On and Off.

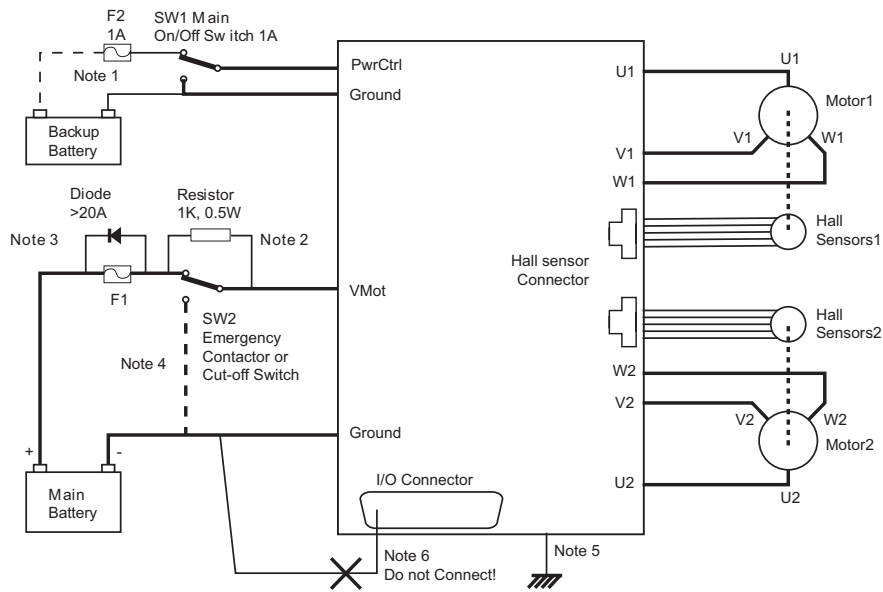

FIGURE 2. Powering the Controller. Thick lines identify MANDATORY connections

Important Warning

Carefully follow the wiring instructions provided in the Power Connection section of the User Manual. The information on this datasheet is only a summary.

Mandatory Connections

It is imperative that the controller is connected as shown in Figure 2, above, in order to ensure a safe and trouble-free operation. All connections shown as thick black lines are mandatory. The controller must be powered On/Off using switch SW1 on the Pwr Ctrl tab. Use a suitable high-current fuse F1 as a safety measure to prevent damage to the wiring in case of major controller malfunction.

Emergency Switch or Contactor

The battery must be connected in permanence to the controller's VMot tabs via a high-power emergency switch or contactor SW2 as additional safety measure. The user must be able to deactivate the switch or contactor at any time, independently of the controller state.

Electrostatic Discharge Protection

In accordance with IEC 61000-6-4, Roboteq Motor Controllers are designed to withstand ESD up to 4kV touch and 8kV air gap. This protection is implemented without any additional external connections required.

Some specifications, such as EN12895, require a higher level of protection. To maximize ESD protection, up to 8kV touch and 15kV air gap, you may connect the metallic heatsink of the controller to your battery negative terminal. [See App Note 062918 for example connections.](#)

Precautions and Optional Connections

- Note 1: Backup battery to ensure motor operation with weak or discharged batteries, connect a second battery to the Power Control wire/terminal via the SW1 switch.
- Note 2: Use precharge 1K, 0.5W Resistor to prevent switch arcing.
- Note 3: Insert a high-current diode to ensure a return path to the battery during regeneration in case the fuse is blown.
- Note 4: Optionally ground the VMot tabs when the controller is Off if there is any concern that the motors could be made to spin and generate voltage in excess of 60V.
- Note 5: Connect the controller's bottom plate to a wire connected to the Earth while the charger is plugged in the AC main, or if the controller is powered by an AC power supply.
- Note 6: Beware not to create a path from the ground pins on the I/O connector and the battery minus terminal.

Single Channel Wiring

On the Single Channel GBL26xxS, the each of the motor wire must be connected to both output tabs of the same letter, as shown in Figure 3, below. Use the Encoders and/or Hall sensors of Channel 1 for operation.

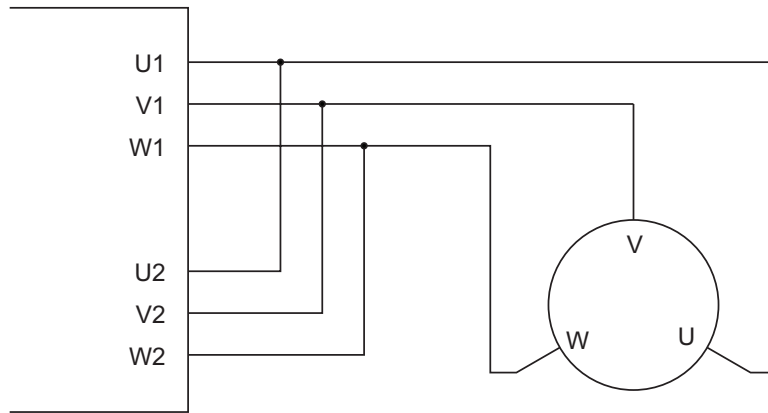

FIGURE 3. Single Channel Wiring Diagram

Important Warning

This wiring must be done only on the single channel version of the controller. Paralleling the wires on a dual channel product will cause permanent damage. Verify that your controller is an GBL2660S before you wire in this manner.

Use of Safety Contactor for Critical Applications

An external safety contactor must be used in any application where damage to property or injury to person can occur because of uncontrolled motor operation resulting from failure in the controller's power output stage.

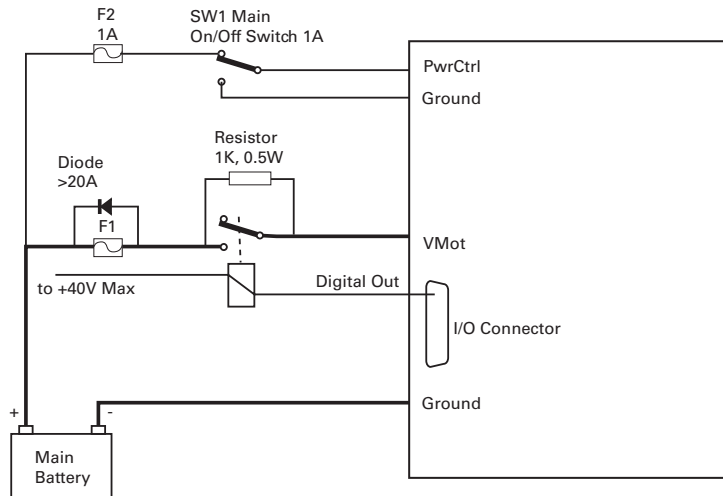

FIGURE 4. Contactor Wiring Diagram

The contactor coil must be connected to a digital output configured to activate when "No MOSFET Failure". The controller will automatically deactivate the coil if the output is expected to be off and battery current of 1A or more is measured for more than 0.5s. This circuit will not protect against other sources of failure such as those described in the "Important Safety Disclaimer" on Page 3.

Controller Mounting

During motor operation, the controller will generate heat that must be evacuated. The published amps rating can only be fully achieved if adequate cooling is provided. Good conduction cooling can be achieved by having the bottom surface of the case making contact with a metallic surface (chassis, cabinet).

Hall Sensors Connection

Connection to the Hall Sensors is done using a special connector on the front side of the controller. The Hall sensor connector is a 6-pin Molex Microfit 3.0, ref. 43645. Pin assignment are in Table 1, below.

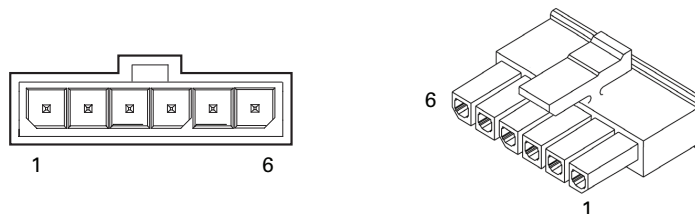

FIGURE 5. Hall Sensors Connector

TABLE 1.

Pin Number	1	2	3	4	5	6
Signal	5V		Hall C	Hall B	Hall A	Ground

Hall Sensor vs Motor Output sequencing

The controller requires the Hall sensors inside the motor to be 120 degrees apart. The controller's 3-phase bridge will activate each of the motor winding according to the sequence shown in the Figure 6, below.

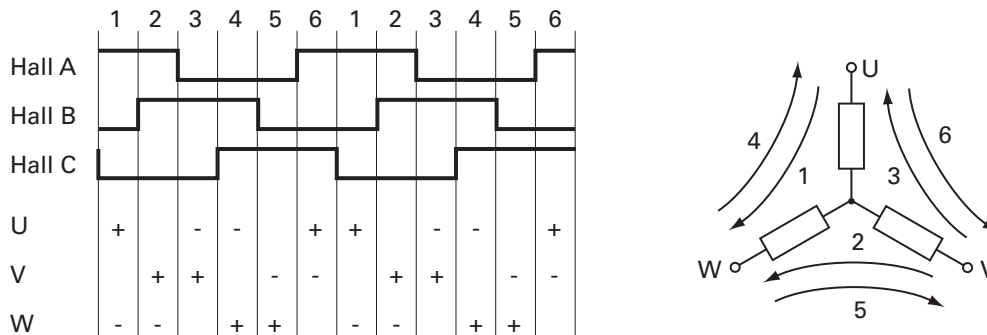

FIGURE 6. Hall Sensors Sequence

Connection to SSI Absolute Encoder

In Sinusoidal Mode, the controller can use motors equipped with absolute angle sensors with SSI interface. When enabled, the SSI signals are found on the 6-pin Molex connector that is otherwise used for the Hall Sensors. The controller issues a clock signal to, and receives data signal from the encoder.

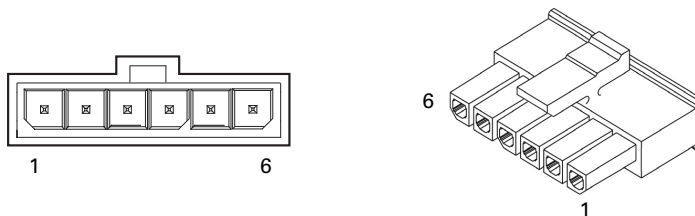

FIGURE 7. Hall Sensor Connector Used for SSI Encoders

TABLE 2.

Pin Number	1	2	3	4	5	6
Signal	5V	Clock -	Clock +	Data -	Data +	Ground

Connection to Analog Sin/Cos Absolute Encoder

The GBL2660 has 4 high-speed analog inputs that can be used to capture absolute angle position from resolvers or magnetic sensors with sin/cos voltage outputs. The signal must be 0-5V max with the 0 at 2.500V. Table 3, below, shows the signals assignment on the 25-pin connector.

TABLE 3.

Signal	Pin Number	Pin Name
Sin1	9	ASIN1
Cos1	10	ACOS1
Sin2	24	ANA7/ASIN2
Cos2	12	ANA8/ACOS2

Connecting Resolver

Resolver wiring is similar to a Sin/Cos sensor with the addition of an excitation signal. Figure 8, below, shows the necessary connections.

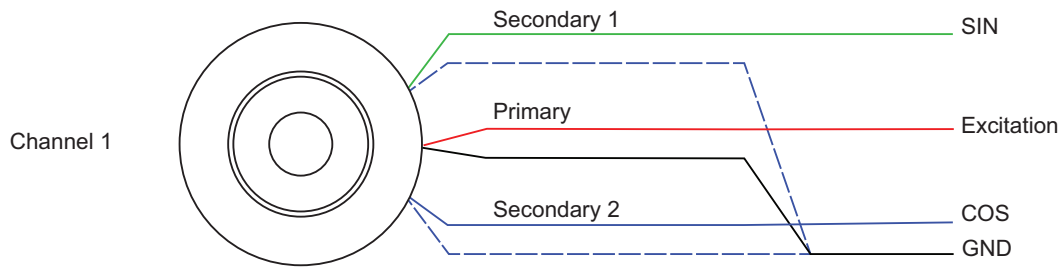

FIGURE 8. Resolver Connections

Table 4, below, shows the signals assignment on the 15-pin connector.

TABLE 4.

Signal	Pin Number	Pin Name
Sin1	9	ASIN1
Cos1	10	ACOS1
Sin2	24	ANA7/ASIN2
Cos2	12	ANA8/ACOS2
Exc	17	ANA4/EXC

Commands and I/O Connections

Connection to RC Radio, Microcomputer, Joystick and other low current sensors and actuators is done via the 25 connector. The functions of many pins vary depending on controller model and user configuration. Pin assignments are found in Table 5, below.

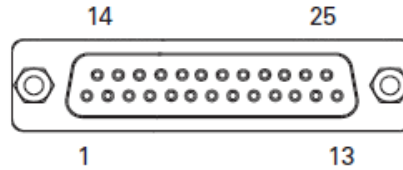

FIGURE 9. Main Connector Pin Locations

TABLE 5.

Connector Pin	Power	Dout	Com	Pulse	Ana	Dinput	Enc	Default Config
1	GND							
14	5VOut							
2			RS TxD					RS232Tx
15				RC1	ANA1	DIN1		RCRadio1
3			RS RxD					RS232Rx
16				RC2	ANA2	DIN2		RCRadio2
4				RC3	ANA3	DIN3		AnaCmd1 (1)
17				RC4	ANA4/EXC	DIN4		AnaCmd2 (1)
5	GND							
18		DOUT1						Motor Brake 1
6		DOUT2						Motor Brake 2
19		DOUT3						Contactator
7		DOUT4						Unused
20			CANH					Unused
8			CANL					Unused
21				RC5	ANA5	DIN5	ENC2A	Unused
9					ASIN1	DIN9		Unused
22				RC6	ANA6	DIN6	ENC2B	Unused
10					ACOS1	DIN10		Unused
23			485+					RS485+
11			485-					RS485-
24				RC7	ANA7/ ASIN2	DIN7	ENC1A	Unused
12				RC8	ANA8/ ACOS2	DIN8	ENC1B	Unused
25	PwrCtrl							
13	GND							

Note 1: Analog command is disabled in factory default configuration.

Default I/O Configuration

While the controller can be configured so that practically any Digital, Analog and RC pin can be used for any purpose, the controller's factory default configuration provides an assignment that is suitable for most applications. The figure below shows how to wire the controller to two analog potentiometers, an RC radio, and the RS232 port. It also shows how to connect two outputs to motor brake solenoids and another output to an external status LED. You may omit any connection that is not required in your application. The controller automatically arbitrates the command priorities depending on the presence of a valid command signal in the following order: 1-RS232, 2-RC Pulse, 3-None. If needed, use the Roborun+ PC Utility to change the pin assignments and the command priority order.

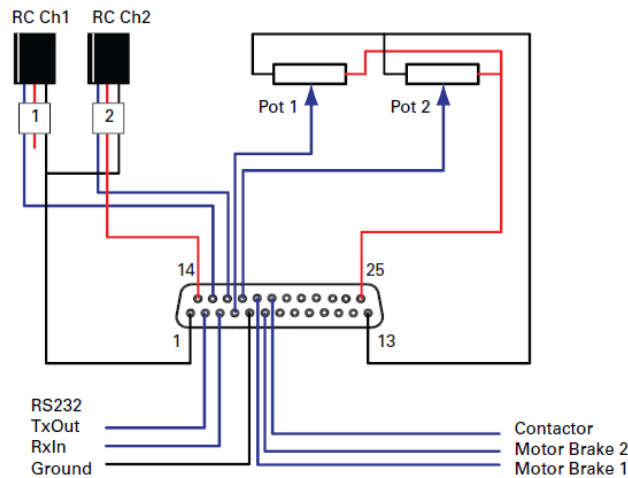

FIGURE 10. Factory Default Pin Assignment

Enabling Analog Commands

For safety reasons, the Analog command mode is disabled by default. To enable the Analog mode, use the PC utility and set Analog in Command Priority 2 or 3 (leave Serial as priority 1). Note that by default the additional securities are enabled and will prevent the motor from starting unless the potentiometer is centered, or if the voltage is below 0.25V or above 4.75V. The drawing shows suggested assignment of Pot 1 to ANA1 and Pot 2 to ANA4. Use the PC utility to enable and assign analog inputs.

USB communication

Use USB only for configuration, monitoring and troubleshooting. USB is not a reliable communication method when used in a electrically noisy environments and communication will not always recover after it is lost without unplugging and replugging the connector, or restarting the controller. Always prefer RS232 communication when interfacing to a computer. USB and CAN can operate at the same time on the GBL2660. Plugging USB to a computer will not disable the CAN interface.

RS485 Communication

The FBL2360 has a half-duplex RS485 interface. Two signals are present on the 25-pin DSub connector for connecting to RS485 networks. Connecting these two wires with the correct polarity is all that is needed to establish a connection. The RS485+ is the positive signal and RS485- is the inverted signal. Once enabled, the RS485 can be used to communicate data under the Modbus protocol, or Roboteq's native serial commands.

Ethernet Communication

Ethernet communication is only available on the E versions of the controller. The connection port is located on the top of the unit for easy and rapid access. Communication occurs via TCP/IP. Commands can be in Serial over TCP and Modbus TCP. Serial over TCP is the preferred method to access all native commands.

Two LEDs are present on the Ethernet jack, as shown in Figure 13. The left Yellow LED will be On when operating as 100 Mbps connection and Off when as 10 Mbps. The right Green LED will blink when data activity is present.

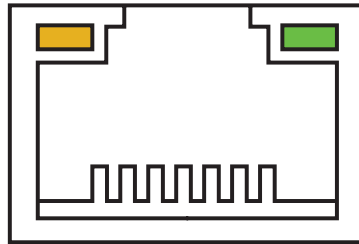

FIGURE 12. Ethernet LED Configuration

Status LED Flashing Patterns

After the controller is powered on, the Power LED will turn on, indicating that the controller is On. The Status LED will be flashing at a 2 second interval. The flashing pattern and color provides operating or exception status information.



FIGURE 11. Normal Operation Flashing Patterns

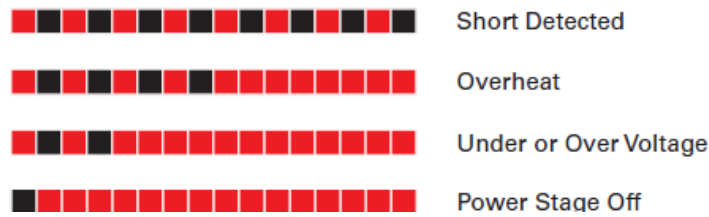

FIGURE 12. Exception or Fault Flashing Patterns

Additional status information may be obtained by monitoring the controller with the PC utility.

Battery Backed Clock and Variables

The controller includes a real-time clock/calendar and RAM storage for user variables. Both the clock and the RAM storage require a battery to continue running and for the stored data not to be lost while the controller is powered down. The battery is not installed by Roboteq. Users who wish to use the clock and/or battery backed RAM variables must install a battery themselves. The battery socket can be reached by removing the 6 screws that are holding the cover. Lift the cover to reach the board and insert a 3V, 12.5mm coin-style battery. Use battery type CR1225 or equivalent.

Measured Amps

The controller includes Amps sensors in line with the motor terminals and on the battery ground terminals. Both Motor Amps and Battery Amps are therefore measured with precision.

Electrical Specifications

Absolute Maximum Values

The values Table 6, below, should never be exceeded, permanent damage to the controller may result.

TABLE 6.

Parameter	Measure point	Min	Typ	Max	Units
Battery Leads Voltage	Ground to VBat			63	Volts
Reverse Voltage on Battery Leads	Ground to VBat	-1			Volts
Power Control Voltage	Ground to Pwr Control wire			63	Volts
Motor Leads Voltage	Ground to U, V, W wires			63 (1)	Volts
Digital Output Voltage	Ground to Output pins			60	Volts
Analog and Digital Inputs Voltage	Ground to any signal pin on 15-pin & Hall inputs			30	Volts

TABLE 6.

Parameter	Measure point	Min	Typ	Max	Units
RS232 I/O pins Voltage	External voltage applied to Rx/Tx pins			30(2)	Volts
Case Temperature	Case	-40		85	°C
Humidity	Case			100 (2)	%
Note 1: Maximum regeneration voltage in normal operation. Never inject a DC voltage from a battery or other fixed source					
Note 2: No voltage must be injected on TxD pin					

Power Stage Electrical Specifications (at 25°C ambient)

TABLE 7.

Continuous Max Current per channel	Measure point	Model	Min	Typ	Max	Units
Battery Leads Voltage	Ground to VBat	All	0 (1)		63	Volts
Motor Leads Voltage	Ground to U, V, W wires	All	0 (1)		63 (2)	Volts
Power Control Voltage	Ground to Power Control wire	All	0 (1)		65	Volts
Minimum Operating Voltage	VBat or Pwr Ctrl wires	All	9 (3)			Volts
Over Voltage protection range	Ground to VBat	All	5	60 (4)	63	Volts
Under Voltage protection range	Ground to VBat	All	0	5 (4)	63	Volts
Idle Current Consumption	VBat or Pwr Ctrl wires	All	50	100 (5)	150	mA
ON Resistance (Excluding wire resistance)	VBat to U, V or W. Ground to U, V or W	GBL2660		1.2		mOhm
		GBL2660S		0.6		mOhm
Max Current for 30s	Motor current	GBL2660			180	Amps
		GBL2660S			360	Amps
Continuous Max Current per channel	Motor current	GBL2660			120 (6)	Amps
		GBL2660S			240 (6)	Amps
Current Limit range	Motor current	GBL2660	10	120 (7)	180	Amps
		GBL2660S	20	240 (7)	360	Amps
Stall Detection Amps range	Motor current	GBL2660	10	180 (7)	180	Amps
		GBL2660S	20	360 (7)	360	Amps
Stall Detection timeout range	Motor current	All	1	500 (8)	65000	milli-seconds
Short Circuit Detection threshold (9)	Between Motor wires or Between Motor wires and round	GBL2660			500 (10)	Amps
		GBL2660S			1000 (10)	Amps

TABLE 7.

Continuous Max Current per channel	Measure point	Model	Min	Typ	Max	Units
Short Circuit Detection threshold	Between Motor wires and VBat	All	No Protection. Permanent damage will result			
Motor Acceleration/Deceleration range	Motor Output	All	100	500 (11)	65000	milli-seconds
Note 1: Negative voltage will cause a large surge current. Protection fuse needed if battery polarity inversion is possible						
Note 2: Maximum regeneration voltage in normal operation. Never inject a DC voltage from a battery or other fixed source						
Note 3: Minimum voltage must be present on VBat or Power Control wire						
Note 4: Factory default value. Adjustable in 0.1V increments						
Note 5: Current consumption is lower when higher voltage is applied to the controller's VBat or PwrCtrl wires						
Note 6: Estimate. Limited by case temperature. Current may be higher with better cooling						
Note 7: Factory default value. Adjustable in 0.1A increments						
Note 8: Factory default value. Time in ms that Stall current must be exceeded for detection						
Note 9: Controller will stop until restarted in case of short circuit detection						
Note 10: Approximate value						
Note 11: Factory default value. Time in ms for power to go from 0 to 100%						

Command, I/O and Sensor Signals Specifications

TABLE 8.

Parameter	Measure point	Min	Typ	Max	Units
Main 5V Output Voltage	Ground to 5V pins on	4.6	4.75	4.9	Volts
5V Output Current	5V pins on RJ45 and DSub15			200 (1)	mA
Digital Output Voltage	Ground to Output pins			60	Volts
Output On resistance	Output pin to ground		0.25	0.5	Ohm
Output Short circuit threshold	Output pin	1.7		3.5	Amps
Digital Output Current	Output pins, sink current			1.5	Amps
Input Impedances (except DIN11-19)	AIN/DIN Input to Ground		53		kOhm
Digital Input 0 Level	Ground to Input pins	-1		1	Volts
Digital Input 1 Level	Ground to Input pins	3		30	Volts
Analog Input Range	Ground to Input pins	0		5.1	Volts
Analog Input Precision	Ground to Input pins		0.5		%
Analog Input Resolution	Ground to Input pins		1		mV
Pulse durations	Pulse inputs	20000		10	us
Pulse repeat rate	Pulse inputs	50		250	Hz
Pulse Capture Resolution	Pulse inputs		1		us
Frequency Capture	Pulse inputs	100		1000	Hz
Note 1: Sum of all 5V Out outputs					

Operating & Timing Specifications

TABLE 9.

Parameter	Measure Point	Min	Typical	Max	Units
Command Latency	Command to output change	0	0.5	1	ms
PWM Frequency	Motor Output	10	18	20	kHz
Closed Loop update rate	Internal		1000		Hz
RS232 baud rate	Rx & Tx pins		115200 (1)		Bits/s
RS232 Watchdog timeout	Rx pin	1 (2)		65000	ms
Note 1: 115200, 8-bit, no parity, 1 stop bit, no flow control					
Note 2: May be disabled with value 0					

Scripting

TABLE 10.

Parameter	Measure Point	Min	Typical	Max	Units
Scripting Flash Memory	Internal		32000		Bytes
Max Basic Language programs	Internal	2000		3000	Lines
Integer Variables	Internal		4096		Words (1)
Boolean Variables	Internal		8192		Symbols
Execution Speed	Internal	50 000	100 000		Lines/s
Note 1: 32-bit words					

Thermal Specifications

TABLE 11.

Parameter	Measure Point	Min	Typical	Max	Units
Case Temperature	Case	-40		85 (1)	°C
Thermal Protection range	Case	80		90 (2)	°C
Power Dissipation	Case			70	Watts
Thermal resistance	Power MOSFETs to case			0.6	°C/W
Humidity	Case			100(3)	%
Note 1: Thermal protection will protect the controller power					
Note 2: Max allowed power out starts lowering at minimum of range, down to 0 at max of range					

Mechanical Specifications

TABLE 12.

Parameter	Measure Point	Min	Typical	Max	Units
Weight	Board		2940 (6.5)		g (lbs)
Power Terminals	Terminal		M6		

